

Alex L. Sessions

Division of Geological and
Planetary Sciences, California
Institute of Technology,
Pasadena, CA, USA

Review**Isotope-ratio detection for gas chromatography**

Instrumentation and methods exist for highly precise analyses of the stable-isotopic composition of organic compounds separated by GC. The general approach combines a conventional GC, a chemical reaction interface, and a specialized isotope-ratio mass spectrometer (IRMS). Most existing GC hardware and methods are amenable to isotope-ratio detection. The interface continuously and quantitatively converts all organic matter, including column bleed, to a common molecular form for isotopic measurement. C and N are analyzed as CO₂ and N₂, respectively, derived from combustion of analytes. H and O are analyzed as H₂ and CO produced by pyrolysis/reduction. IRMS instruments are optimized to provide intense, highly stable ion beams, with extremely high precision realized *via* a system of differential measurements in which ion currents for all major isotopologs are simultaneously monitored. Calibration to an internationally recognized scale is achieved through comparison of closely spaced sample and standard peaks. Such systems are capable of measuring ¹³C/¹²C ratios with a precision approaching 0.1‰ (for values reported in the standard delta notation), four orders of magnitude better than that typically achieved by conventional “organic” mass spectrometers. Detection limits to achieve this level of precision are typically <1 nmol C (roughly 10 ng of a typical hydrocarbon) injected on-column. Achievable precision and detection limits are correspondingly higher for N, O, and H, in that order.

Keywords: Combustion interface / Compound-specific isotope analysis / GC-isotope-ratio mass spectrometry / Isotope-ratio-monitoring / Pyrolysis interface

Received: January 3, 2006; revised: June 13, 2006; accepted: June 14, 2006

DOI 10.1002/jssc.200600002

1 Introduction

The methods and instrumentation used to measure the abundance of stable isotopes with very high precision have been developed primarily within the Earth Sciences. Although invented more than 65 years ago [1, 2], the isotope-ratio mass spectrometer (IRMS) was not successfully adapted as a detector for GC until the late 1970s [3, 4]. Even today, high-precision isotope-ratio detection of GC analytes remains a somewhat specialized endeavor, and is practiced by no more than a few hundred laboratories worldwide. At the same time, interest in isotope-ratio detection is growing rapidly, fueled by a combination of increasingly automated instrumentation and a growing appreciation for the potential of stable-isotopic labeling and fingerprinting. Thus hyphe-

nated GC and IRMS methods, once the nearly exclusive domain of biogeochemists and the petroleum and flavor/fragrance industries, are now appearing in a broad cross-section of analytical sciences. The goal of this review is to provide a general overview and summary of the capabilities, limitations, and requirements of isotope-ratio detection for the general community of gas chromatographers. It is neither an exhaustive history of what has come before, nor a detailed primer on specific methods. A subordinate goal is to provide a more complete description of practices relevant to the measurement of hydrogen isotopes (²H/¹H or D/H), a capability that has become widespread only within the past ~5 years.

Two further restrictions on the scope of this review should be recognized. The first is that only systems employing GC as a primary means for analyte separation are discussed. As such, the focus here is on volatile and semivolatile organic molecules. Indeed, elemental analyzers and other devices employing GC for the purification of reaction products are far more abundant, are capable of analyzing both organic and inorganic materials, and are the topic of other reviews [5–7]. The second restriction is that of specialized systems designed specifically

Correspondence: Dr. Alex L. Sessions, Division of Geological and Planetary Sciences, California Institute of Technology, 1200 E California Blvd, Pasadena, CA 91125, USA.

E-mail: als@gps.caltech.edu.

Fax: +1-626-6830621.

Abbreviations: IRMS, isotope-ratio mass spectrometer; SPME, solid-phase microextraction

Table 1. Relevant characteristics of the light stable isotopes

Isotopes	Sample gas	Interface type	Reference standard (name) ^{a)}	Isotope ratio of standard ^{a)}	Theoretical sensitivity (nmol) ^{b)}	Typical precision (‰) ^{c)}	Typical sensitivity (nmol) ^{d)}	First commercial GC-IRMS instrument
² H/ ¹ H	H ₂	Pyrolysis	Water (VSMOW)	0.00015576	21	2–5	10–50	1998
¹³ C/ ¹² C	CO ₂	Combustion	Carbonate (VPDB)	0.011224	0.024	0.1–0.3	0.1–5	1988
¹⁵ N/ ¹⁴ N	N ₂	Combustion/ reduction	Air (AIR)	0.003663	0.11	0.3–0.7	1–10	1992
¹⁸ O/ ¹⁶ O	CO	Pyrolysis	Water (VSMOW)	0.0020052	0.19	0.3–0.6	4–14	1996
³⁴ S/ ³² S	SO ₂	NA ^{e)}	Troilite ^{f)} (VCDT)	0.04416	0.0048	NA	NA	NA
³⁷ Cl/ ³⁵ Cl	CH ₃ Cl ^{g)}	NA	Chloride (SMOC)	0.3196	0.00066	NA	NA	NA

a) See [78] for a complete description of international standards and reference materials.

b) Nanomoles of gas required by the IRMS to achieve 0.1‰ SD when operating at the shot-noise limit for a sample containing a natural abundance of the rare isotope. Ionization efficiencies are estimated at 0.1, 1.2, 0.9, 0.9, 1.7, and 2.7 (10⁻³ ions/molecule) for H₂, CO₂, N₂, CO, SO₂, and CH₃Cl, respectively. The calculation accounts for the fact that two moles of H and N are required for each mole of sample gas.

c) Typical SD (1σ) reported for isotopic measurements by GC-IRMS. Values were obtained from a survey of published results from 2000 to 2005.

d) Sample required to obtain the typical precision listed at left. Values refer to nanomoles of the analyzed element (H, C, N, and O) injected on-column.

e) Sulfur could likely be combusted to SO₂ and measured by existing IRMS instruments. However, no GC-IRMS analyses of organic S have yet been reported.

f) Troilite is an FeS mineral found in meteorites.

for measuring isotope ratios with very high precision at or near their natural abundance. Virtually any mass spectrometer is capable of measuring isotopic abundance to within a few percent. In contrast, the methods described here achieve measurement precision that is at least four orders of magnitude greater, *i.e.*, in the low part-per-million range. Details of the procedures used to achieve this extraordinary precision constitute the bulk of this review.

2 Background

The fundamental scientific and methodological aspects of stable isotope analysis have filled many reviews, culminating recently in [8]. Although the historical development of this field is well beyond the scope of the current review, its past has profoundly influenced the current state of the science, to say nothing of its vocabulary. No lesson in isotopic analytical chemistry can be fully coherent without at least some reference to the past and introduction to the vernacular. Only the barest of bones are provided here, with the hope that interested readers will pursue some of the excellent reviews that provide more thorough historical coverage [6, 9–13].

2.1 Isotopes of interest

With the exception of fluorine, all of the elements common to organic molecules possess two or more stable isotopes (summarized in Table 1). They are collectively referred to as the “light stable isotopes” and share the common feature that their relative abundances vary

measurably in natural materials as a result of differences in rate constants for physical and chemical processes (isotope effects). Criss [14] has recently reviewed isotope effects in geologic materials, and many other reviews are available in the chemical and biological literature [15–21]. Three of these light elements also possess naturally occurring radioactive isotopes (³H, ¹⁴C, and ³⁵S), but they have not yet been analyzed using the methods described here. The more precise designation of “stable isotopes” is thus often abbreviated in the relevant literature, *e.g.*, “carbon-isotopic analysis” referring to the abundance of ¹²C and ¹³C but not ¹⁴C.

Mass-spectrometric methods for measuring variations in the natural abundance of these isotopes have been developed for all of the elements listed in Table 1. However, only a subset of these elements are currently amenable to hyphenated GC-IRMS methods. Analysis of the stable isotopes of C, N, and H are common today, those for O isotopes are just beginning to appear, while for S and Cl they remain on the horizon. S-isotopic analysis by GC-IRMS is mainly limited by the very low concentrations of organic sulfur [22]. The lack of an appropriate method for continuously converting halocarbons into suitable chemical forms for analysis has prevented isotopic analysis of Cl and Br.

2.2 Terminology

The stable isotope community has developed a vocabulary that is distinct from much of mainstream analytical MS, in part because of its evolution in relative isolation

within the Earth Sciences. By convention, the relative abundance of stable isotopes is always referenced to the heavy isotope; thus an increase in the $^{15}\text{N}/^{14}\text{N}$ ratio would be reported rather than a decrease in the $^{14}\text{N}/^{15}\text{N}$ ratio. This convention is codified in the ubiquitous “delta” notation that was first described by Urey [23] and that is still widely used today

$$\delta^{13}\text{C}_{\text{sam}} = \frac{(R_{\text{sam}} - R_{\text{std}})}{R_{\text{std}}} \times 1000\text{‰} \quad (1)$$

where R is the absolute $^{13}\text{C}/^{12}\text{C}$ ratio of the sample or of an internationally accepted reference standard (summarized in Table 1). The delta value is thus the relative difference in isotope ratio between sample and standard, and is expressed in units of permil (‰) or parts per thousand, by analogy with the more common percent (%). Equivalent delta notation is used for all of the stable isotopes, *i.e.*, $\delta^2\text{H}$ (more commonly δD), $\delta^{15}\text{N}$, $\delta^{18}\text{O}$, $\delta^{34}\text{S}$, and $\delta^{37}\text{Cl}$. Delta notation serves three useful functions. First, it emphasizes the fact that we measure the relative, rather than absolute, abundances of stable isotopes (see Section 2.3) and that uncertainties in absolute isotopic abundance always greatly exceed those for relative abundance. Second, delta notation allows us to focus on and compactly report very small changes in isotope ratio by eliminating many unchanging decimal places. Thus, a water sample with a D/H ratio of 0.0001568 ± 0.0000008 would be reported as $\delta\text{D} = 6.4 \pm 1.3\text{‰}$. Positive δ values represent an enrichment of the heavy isotope relative to the international standard, while negative values represent a depletion of the heavy isotope. The jargon of isotopic analysis has grown to include “del” (delta value), “delta-del” (the difference between two delta values, equivalent to the isotopic fractionation), and “heavy” or “light” delta values (enriched or depleted in the heavy isotope), but the use of these terms in print is discouraged. Third, delta values can to a good approximation be added linearly [14], greatly facilitating many calculations. For example, the isotopic composition of an equimolar mixture of two waters having δD values of 0.0 and -24.0‰ would be -12.0‰ .

Isotope-ratio MS is not generally employed to measure isotope effects on rate constants directly. Rather, it is used to measure the resulting differences in isotopic distribution between reactants and products, or between several products, termed the “isotopic fractionation.” Fractionation is defined exactly as the ratio of isotope ratios (where it is given the symbol α), and approximately as the arithmetic difference between two delta values (Δ) (for a review of these and other forms, see [14]). Although fractionations and isotope effects are not strictly interchangeable, their distinction in the literature is often blurred. Thus “fractionation” is commonly used to describe both the measurable difference in isotope ratios

between two samples, as well as the characteristic separation of isotopes accompanying a particular reaction or process. Hayes [12] provides a particularly lucid description of the distinction.

2.3 Principles of stable isotope analysis

All methods for measuring stable-isotopic abundance with very high accuracy have three common elements. First, analytes are converted to a simple molecular form possessing few isotopologs, *i.e.*, H_2 , CO_2 , *etc.* (see Table 1). Second, highly specialized mass spectrometers that maximize ion beam current and stability at the expense of mass resolution and dynamic range are employed (described in Section 5). Third, a system of differential measurements is employed in which sample and standard are repeatedly compared [2].

The first of these requirements arises for several reasons. Virtually all organic molecules possess two or more elements of varying isotopic abundance. Thus, a comparison of trimethylamine molecules with masses 59 and 60 amu would confound the abundances of ^2H , ^{13}C , and ^{15}N . Because the isotopic composition of different elements can vary independently, and because IRMS instruments do not have sufficient mass resolution to distinguish the isotopomers, it is not possible to parse the ratio of molecular masses into its isotopic constituents with sufficient accuracy. Moreover, many organic species can participate in proton-exchange reactions in the ion source of the mass spectrometer, leading to further confusion (*e.g.*, $\text{H}_2^{17}\text{O}^+$ vs. $\text{H}_3^{16}\text{O}^+$). Finally, the ionization and transmission of molecules in the spectrometer is itself accompanied by substantial isotope effects that depend on molecular form. This hurdle can be overcome only by utilizing truly differential measurements of sample and standard, an approach that requires the two to be of identical chemical (though not isotopic) composition. In theory this could be accomplished by preparing standards of known isotopic composition for each organic structure to be studied, but this is highly impractical.

The conversion of organic analytes to gaseous form was traditionally carried out by combustion or reduction in sealed quartz tubes, with the products cryogenically purified in vacuum lines and transferred en masse to the IRMS (*e.g.*, [24]). Such methods are today commonly referred to as “offline” preparation. A major hurdle in the coupling of GC and IRMS instruments was the development of suitable chemical reaction interfaces that provide continuous, quantitative conversion of analytes while maintaining chromatographic peak resolution (“online” preparation). Combustion interfaces, used for analysis of ^{13}C and ^{15}N , were developed in the early 1980s [3, 4, 25–27] whereas pyrolysis interfaces for ^2H and ^{18}O were developed in the late 1990s [28–31]. These interfaces are one of the most specialized aspects of hyphenated

GC-IRMS systems, and remain a focus of ongoing development.

The system of differential measurements that was first developed by Harold Urey and his students [2] remains the cornerstone of high-precision isotopic measurements. In essence, ion currents are measured simultaneously for two or more masses (*e.g.*, m/z 28 and 29, corresponding to $^{14}\text{N}^{14}\text{N}^+$ and $^{15}\text{N}^{14}\text{N}^+$ ions) using multiple detectors. Ion-current ratios are then compared between sample and standard gases of the same chemical form. Although the absolute isotopic abundances are known only poorly, the difference in ion-current ratios is exactly proportional to the difference in isotope ratios, allowing precise calculation of delta values. Several excellent reviews of these procedures can be recommended [9, 11, 13].

Such differential measurements were originally – and for some applications still are – conducted by repeatedly comparing sample and standard gases stored in two reservoirs (“bellows”). Gas flows continually out of each reservoir, and a series of valves allows the user to rapidly and repeatedly alternate the introduction of both gases to the IRMS. Termed “dual inlet” MS, this approach is used today where the highest levels of precision are required. It is, unfortunately, not applicable to the dynamic peaks that emerge from a GC. The solution that is in place, and which was pioneered by John Hayes and his students in the 1980s, is to integrate ion currents across an entire chromatographic peak (measuring multiple isotopologs simultaneously), and then to compare them to a standard eluting at a different time in the chromatogram [32]. This procedure, commonly referred to as “isotope-ratio monitoring” or “continuous-flow” MS, is illustrated in Fig. 1. Although seemingly simple, making such comparisons with sufficient precision required numerous advances in instrument stability and linearity, noise reduction, and signal and data processing. Commercial instrumentation for hyphenated GC-IRMS was not available until 1988, more than a decade after the first reports describing such a system [3, 4]. The advance marked a revolution in stable-isotope MS that has dramatically increased the speed, sensitivity, and flexibility of stable-isotopic measurements [32]. The division between dual-inlet (offline) and isotope-ratio monitoring (online) methods remains a first-order distinction in the stable isotope community.

2.4 Precision and sensitivity in isotope-ratio detection

The system of differential measurements eliminates most sources of systematic error affecting isotope ratios. For this reason, precision – rather than accuracy – reigns supreme as the metric of analytical performance in isotope-ratio measurements. The attainable precision of all

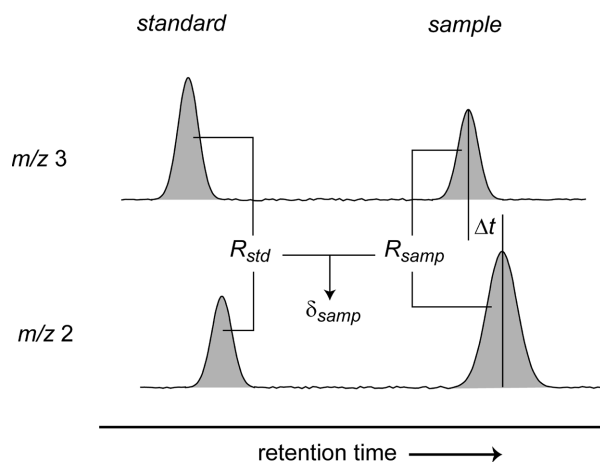

Figure 1. A schematic chromatogram illustrating the principle of isotope-ratio monitoring analysis. Two or more ion currents (here masses 2 and 3, corresponding to H_2^+ and HD^+) are measured simultaneously by multiple Faraday detectors. Peak areas for both isotopologs of each analyte are then computed, taking into account the time shift due to isotope chromatography (Δt , greatly exaggerated in this figure for clarity). Peak areas of the isotopologs are then compared to compute the ion-current ratio (R) for each analyte. Finally, ion-current ratios are compared between sample and standard to calculate the delta value (here δD) of the sample. In a typical analysis, the sample is compared to two or more isotopic standards.

isotope-ratio measurements is governed by two factors: the practical limitation of instrumental noise and the fundamental limitation of counting statistics. While both are applicable to all forms of MS, the latter is particularly important in isotope-ratio MS and is discussed briefly here. The reader is referred to Hayes [12] for a more complete discussion. The ion beam generated by a mass spectrometer contains a finite but random (in the time domain) distribution of individual ions. Put another way, if we measured an ion beam containing on average 10^6 ions/s over a series of 1 s intervals, we might measure 999 500 ions one second and 1 000 025 ions the next. Due to the discrete nature and stochastic distribution of ions, the precision with which we would estimate the average ion current increases as the square root of the number of ions counted, a property governed by the Poisson distribution and familiar to all scientists that rely on counting finite numbers of randomly distributed particles. The attainable precision for isotope-ratio measurements is thus fundamentally limited by the number of ions of the rare isotope that are counted, known as the “shot-noise” limit [33]. This limitation combines both the ionization efficiency of the mass spectrometer and the relative abundance of the rare isotope. Precision and sensitivity are thus closely coupled in isotope-ratio measurements, and sensitivity (when defined as the required sample size) can only be discussed meaningfully if the

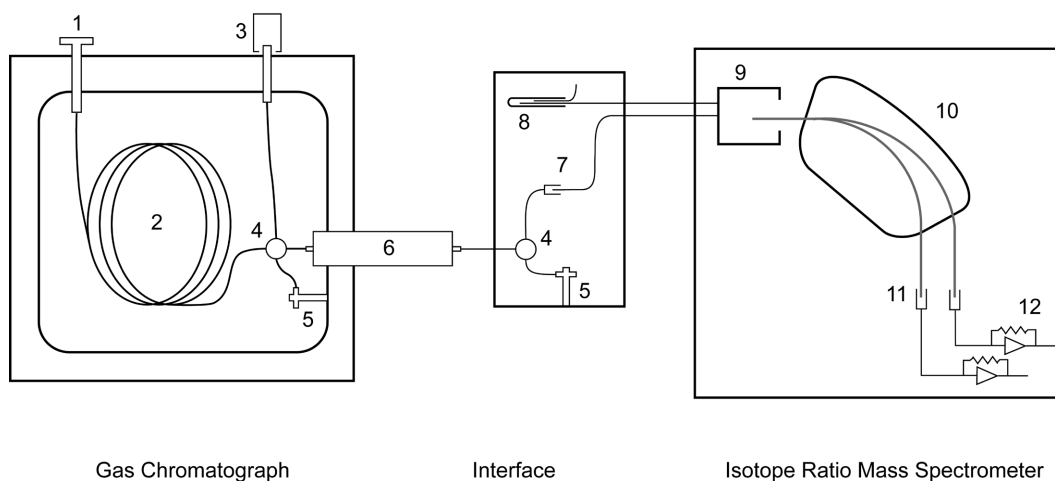

Figure 2. Schematic of a typical GC-IRMS system configured for D/H analysis. The type of postcolumn reactor and interface components vary for different elements and are described in Section 4. Numbered components: 1, injector; 2, analytical column; 3, FID; 4, unions; 5, backflush valves; 6, pyrolysis reactor; 7, open split; 8, reference gas injector; 9, electron impact ionization source; 10, magnetic-sector mass analyzer; 11, Faraday detectors; 12, analog electrometers.

required isotopic precision is specified. Table 1 compiles the theoretical sample sizes required to reach 0.1‰ precision for each isotope when operating at the shot-noise limit.

For carbon, modern methods and instrumentation have reduced noise sources to such a level that isotopic measurements commonly achieve precision that is within a factor of 10 of that imposed by the shot-noise limit [33]. For other elements, increased noise sources and systematic bias due to analyte handling and conversion lead to worse precision, such that achievable precision is commonly a factor of 100 or more above that of the shot-noise limit [34]. Table 1 documents the typical levels of precision reported for GC-IRMS analyses of real samples, and the sample sizes used to obtain those data. This latter metric of sensitivity refers to moles of sample injected into the GC, and hence incorporates a two- to four-fold splitting of GC effluents in the interface (see Section 4). The reader is reminded that significantly greater sensitivity can be achieved if proportionately poorer isotopic precision can be tolerated, such as for analytes that have been artificially enriched with the rare isotope.

2.5 Instrumentation

Analytical systems for stable isotope detection of GC analytes are commercially available and are commonly sold as three discrete units: the GC, the IRMS, and the interface between them. A generic system is shown in Fig. 2. There are relatively few specific requirements for the GC, and most commercial instruments are useable with only minor modification (Section 3). IRMSs are of course highly specialized, though modern instruments are at least flexible enough to handle both dual-inlet and iso-

tope-ratio monitoring applications, as well as all of the isotopes listed in Table 1. Interfaces are sold either as combustion or pyrolysis devices, with both flavors commonly incorporated into a single apparatus. Complete GC-IRMS systems are currently available from two commercial vendors, ThermoElectron (www.thermo.com; formerly Finnigan MAT) and GV Instruments (www.gvinstruments.co.uk; formerly part of Waters, Micromass, Fisons, and VG), with prices for a complete system starting at ~\$150 000. While still considerably more bulky than benchtop quadrupole GC-MS systems, the smallest of these are now roughly the size of an undercounter dishwasher. Modern software controls all elements of the GC-IRMS system, though users are still restricted to the software provided by each vendor for processing chromatographic and isotopic data.

Perhaps not surprisingly, users remain deeply divided with regard to the appropriate nomenclature for describing hyphenated GC-IRMS systems. Historical precedence goes to Matthews and Hayes [4] who coined the term “isotope-ratio-monitoring GCMS” (irmGCMS), although this is rarely used today. The equally generic “GC-IRMS” was introduced in the 1980s. “Continuous-flow” (CF)-IRMS and, less commonly, “carrier-gas IRMS” are also in use. A more detailed etymology is provided by Douthitt [35]. Most reports today use acronyms describing the nature of the GC-to-IRMS interface, including GC-C-IRMS for combustion or GC-P-IRMS (or GC-py-IRMS) for pyrolysis. ThermoElectron has substituted “thermochemolysis” (TC) for pyrolysis in the names of their commercial products, resulting in GC-TC-IRMS. A minimalist contingent uses “compound-specific isotope analysis” (CSIA) to refer to all GC-based isotope-ratio measurements, though this

leads to ambiguity when other methods are used to analyze pure compounds. At present, an unequivocal description of analytical methodology requires a retreat to verbiage.

3 GC

Most GC instrumentation and methods can be readily adapted to isotopic measurements. Helium must be used as the carrier gas because H₂ is incompatible with the chemical reaction interfaces. Methods for sample preparation are beyond the scope of this review, and the reader is referred to the recent review by Meier-Augenstein [36]. The following aspects of GC of particular interest to isotope-ratio detection are highlighted here: (i) injection of analytes without fractionation, (ii) baseline separation of analytes and isotope chromatography, (iii) column capacity, and (iv) special considerations for derivatizing reagents.

3.1 Injection methods

A unique constraint of isotope-ratio detection is the necessity for injection of analytes without isotopic fractionation. When samples are quantitatively transferred to the analytical column, such as with on-column injection, no fractionation is possible. However, if the transfer is not quantitative, isotopic fractionation may arise due to isotope effects on the vaporization and diffusion of isotopically substituted molecules. For semivolatile analytes, splitless, on-column, and programable-temperature vaporization (PTV) injection methods have all been widely used with success. Some ambiguity exists with regard to isotopic fractionation associated with split injection. Several published reports have found no significant fractionation at any split ratio (*e.g.*, [37, 38]) while other users have reported (though not published) problems at low (<20:1) injector split ratios. Solid-phase microextraction (SPME) has been reported as a viable concentration and injection technique for water-soluble organics [39], although there is a small isotopic fractionation associated with the adsorption process. Injection of volatile organic compounds (VOCs) is more difficult because of associated evaporative fractionations. Harris *et al.* [40] compared purge-and-trap and headspace SPME methods for ¹³C analysis of gasoline-range hydrocarbons, and concluded that both methods can yield accurate and precise results if injection conditions are carefully optimized. Dayan *et al.* [41] used headspace SPME to measure ¹³C in chlorinated solvents, and observed a consistent 0.3‰ enrichment of ¹³C relative to bulk (offline) analyses. Zwank *et al.* [42] have recently provided the most comprehensive comparison of on-column, splitless, split (50:1), SPME, and purge-and-trap injection methods for volatile hydrocarbons and halocarbons. They conclude that while “all methods are suitable for environmental appli-

cations,” on-column injection provided the best isotopic precision while purge-and-trap provided the lowest detection limits. Analysis of atmospheric VOCs has thus far been based primarily on cryogenic concentration from large-volume samples, and is reviewed by Goldstein and Shaw [43]

3.2 Peak resolution

The most important function of the GC is to provide absolute baseline resolution between analyte peaks. While simple to understand, the severity of this requirement is often underappreciated [10, 36]. Analytes are subject to chromatographic separation based on isotopic substitution, a fact well known to chromatographers using perdeuterated molecules as internal standards. Surprisingly, high-resolution chromatographic columns will (partially) separate molecules containing just one D atom from those containing none, as well as those containing one ¹³C, ¹⁵N, *etc.* This is true even for C₄₀ hydrocarbons and above, where the mass difference between singly substituted isotopologs is only 0.2%. The difference in retention time is only fractions of a second, but the inevitable result is that each chromatographic peak is isotopically inhomogeneous in the time domain [44, 45]. This point is emphasized by plotting the instantaneous ¹³C/¹²C (or D/H, *etc.*) ratio of a peak measured with high precision as a function of time (Fig. 3). Accurate measurement of the isotopic composition of a peak thus requires integration over the entire peak, from baseline to baseline, without interference from coeluting compounds [44]. Attempts at mathematical deconvolution of coeluting peaks have had some success [44, 46, 47], but have not yet been incorporated into commercial software.

The problem is made even more onerous by an abundance of plumbing in the GC interface (see Section 4), together with the chemical conversion process itself, all of which tend to degrade peak shape and induce tailing. In H-, O-, and N-isotopic analyses, where sample-size requirements are typically an order of magnitude higher than for C (*cf.* Table 1), column overloading is common and peak fronting also becomes problematic. For many environmental samples, where crowded chromatograms are common, separation of chromatographic peaks remains the single most important factor limiting the acquisition of accurate isotopic data. Despite this, chromatographic conditions utilized in most GC-IRMS systems are still quite rudimentary, employing a single 30 or 60 m capillary analytical column. Reports of 2-D GC coupled to isotope-ratio detection are beginning to appear, particularly within the natural products literature [48, 49]. The use of pressure-tunable tandem column GC (*e.g.*, [50]) for isotope-ratio measurements has not been reported, but could offer multiple benefits. Fast GC

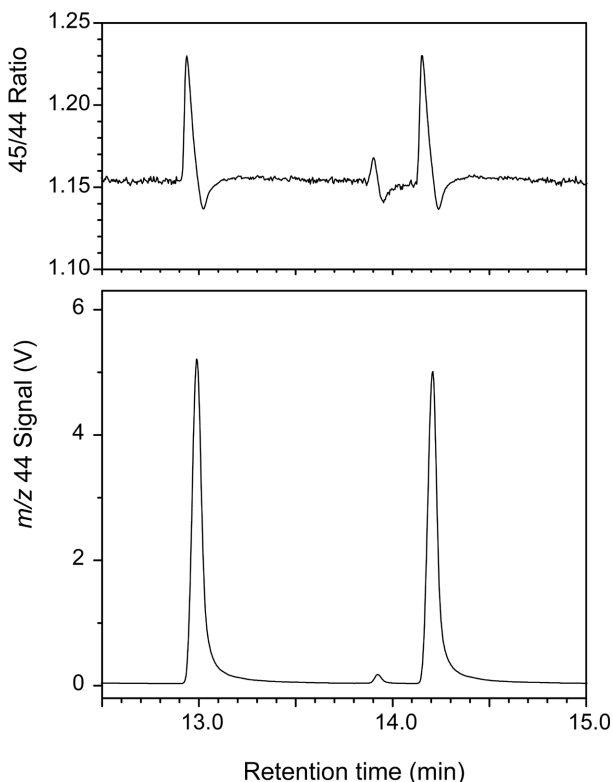

Figure 3. Partial chromatogram showing the mass 44 ($^{12}\text{CO}_2$) ion current (bottom) and the instantaneous mass 45/44 ion-current ratio (top) from a GC-combustion-IRMS analysis. The two large peaks are icosane and heneicosane, while the small peak is an unknown contaminant. The 45/44 ion-current ratio varies strongly across each peak as a result of the slightly shorter retention time for molecules containing one ^{13}C atom. Noticeable peak tailing is induced by the combustion interface and associated plumbing.

and comprehensive GC \times GC methods appear unsuitable because of the very fast detector response times required.

3.3 Column capacity

The sample requirements listed in Table 1 are provided in units of elemental abundance (*e.g.*, nmol N injected). In contrast, chromatographic separations are affected by the *molecular* mass of injected analyte. Thus, while a request for 20 nmol of H_2 may not seem extravagant to the mass spectroscopist, the chromatographer will blanch when this is translated into a requirement for 336 ng of cholesterol injected on-column. For analyses of organic N and O, the problem is further exacerbated by their low elemental abundance. The essential point is that, for all isotopes except ^{13}C , analyte requirements are large relative to the capacity of typical high-resolution capillary columns for all but the most volatile compounds. Peak broadening due to inadequate column capacity often exceeds that due to plumbing. Increasing

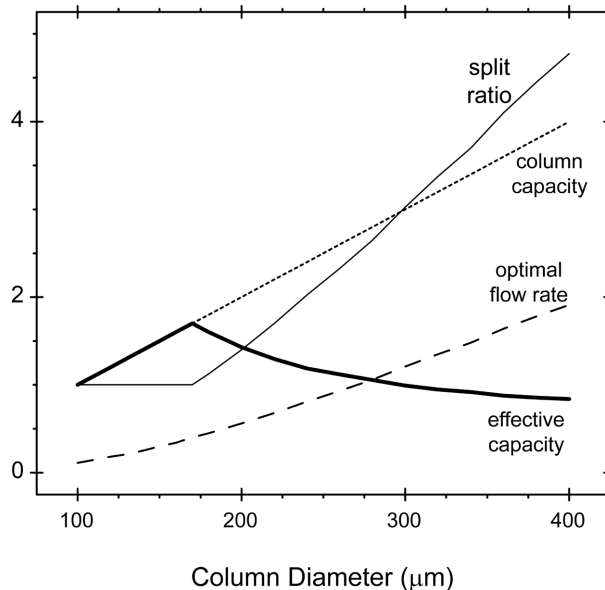

Figure 4. Graph showing the theoretical effects of GC column inner diameter on its effective capacity for delivering analytes to the IRMS. Units for the y -axis vary with each curve. Dotted line: absolute column capacity relative to a value of 1.0 for the smallest column diameter (arbitrary units). Dashed line: optimal carrier-gas flow rate (mL/min) calculated for a 30 m column at 100°C with the outlet at 1 atm pressure using He carrier gas. Thin solid line: interface split ratio (dimensionless), calculated as GC flow rate/IRMS flow rate. The minimal value of 1 is achieved when the entire GC flow is transferred to the IRMS at a flow rate of 0.4 mL/min. Bold solid line: effective column capacity (arbitrary units), calculated as absolute capacity/interface split ratio. All curves are derived from theoretical calculations, not measured data.

stationary-phase film thickness can improve column capacity, but at the expense of peak resolution. The film thickness chosen for most applications represents a necessary compromise, and for H-, N-, and O-isotopic analysis columns with thicker films are frequently used for GC-IRMS than for GC-MS.

The effects of column diameter on its capacity are – for this application – counterintuitive. For a given stationary-phase thickness, increasing column radius (r) increases capacity in proportion to r . At the same time, the optimal volumetric flow rate for the column increases approximately as r^2 . Because the IRMS can accept a maximum of ~ 0.4 mL/min of He carrier gas, any flow above this amount must be discarded and so the “interface split ratio” (flow through GC/flow into IRMS) increases rapidly. These competing interests are summarized in Fig. 4, which shows that smaller columns provide a higher effective capacity because the interface split ratio decreases faster than does the absolute column capacity. The lower limit for this trend is provided by a column with optimal flow rate of ~ 0.4 mL/min.

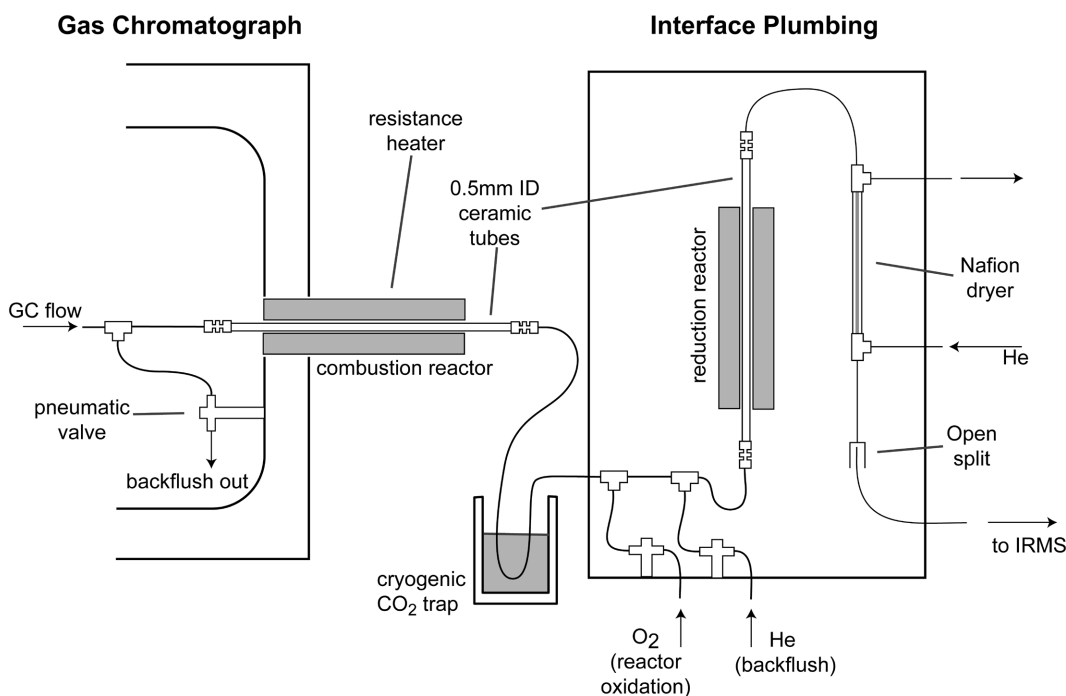

Figure 5. Schematic outline of a typical GC-IRMS interface configured for N-isotopic analysis. For analyses of ^{13}C , the cryogenic CO_2 trap is eliminated and the reduction reactor is sometimes removed. For analyses of ^2H and ^{18}O , the CO_2 trap, reduction reactor, and Nafion drier are removed, and the combustion reactor is replaced by a pyrolysis reactor. Operation of the various components is described in the text.

3.4 Derivatization

Derivatization of organic functional groups is common in GC-IRMS, just as in GC-MS. For C and N analyses, the primary function is to improve chromatographic separation. Meier-Augenstein [10] provides an extensive review of derivatizing reagents common in this application, and criteria for their selection. The requirements for derivatizing reagents include (i) quantitative reaction with analytes, (ii) limited addition of the element being analyzed (*i.e.*, isotope dilution), (iii) chromatographic effects, and (iv) no detrimental effects on the reaction interface. For O and H analyses, an additional function is to remove atoms that undergo rapid isotopic exchange. For example, O-bound H in hydroxyl and carboxyl moieties can undergo exchange with atmospheric moisture in the lab on timescales of minutes to hours, leading to errors in the measured isotopic composition [51]. Replacing carboxyl H with a methyl ester moiety eliminates this exchangeable position, and while the added methyl H must still be accounted for it is at least a stationary target.

Correction for atoms added by a derivative is conceptually simple but sometimes problematic. For C and N, all that is required is to measure the isotope ratio of a standard compound before and after derivatization (*e.g.*, phytol vs. phytol-TMS), and calculate the isotopic composition of the added group by mass balance. Problems

arise in particular for H because it is impossible to accurately measure the D/H ratio of C-bound H in the molecule without first removing exchangeable H (*e.g.*, the lone hydroxyl H in the phytol example). This pitfall has generally been overcome either by measuring the D/H ratio of the carboxylate salts of organic acids (phthalic acid or succinic acid [52]) – which can then be derivatized and measured – or of the bulk derivatizing reagents acetic anhydride or BSTFA [53, 54]. Such measurements must be performed by offline combustion/reduction, and require highly specialized techniques. Arndt Schimmelmann (Indiana University) has recently made aliquots of isotopically characterized phthalic acid and acetic anhydride available to the community for this purpose (<http://php.indiana.edu/%7easchimme/hc.html>), but there is a clear need for other types of standards. The susceptibility of organic O, particularly carboxyl O, toward isotopic exchange during typically laboratory procedures has not been systematically investigated.

4 Interfaces for GC and IRMS

The interface between GC and IRMS instruments (Fig. 5) serves four primary purposes: (i) it must quantitatively convert analytes to the common molecular form needed for measurement, (ii) it removes undesirable reaction products from the carrier gas stream, (iii) it must divert the solvent peak from reaching the chemical conversion

reactor, and (iv) it buffers the relatively large pressure fluctuations that occur when discrete organic peaks are combusted or pyrolyzed. All of this must be accomplished while maintaining chromatographic resolution. The first two requirements are met in different ways depending on the measured element, while the latter two are the same for all elements.

4.1 Chemical conversion and purification

The heart of the GC-IRMS interface is a high-temperature chemical reactor that continuously and quantitatively transforms complex organic molecules into a single gaseous species (Fig. 5). Two general strategies are utilized – combustion and pyrolysis/reduction – and each is optimized for the element whose isotopic composition is being measured. Combustion is used for C and N, whereas pyrolysis is used for H and O. Because of these differences the interfaces used for each element are discussed separately in the following subsection, although in practice many components are shared for all elements.

4.1.1 Carbon isotopes

Combustion of organic molecules to CO₂ can be rapid and quantitative, providing a convenient interface for carbon-isotopic analyses. The optimal reactor conditions for achieving both complete combustion and long lifetime are the subject of some debate, and vary with analyte chemistry. Merritt *et al.* [25] provide a comprehensive discussion of the subject. The two primary considerations are temperature and source of oxidizing power. Higher temperatures lead to more rapid and complete combustion, but also more rapid loss of oxidizing power. CuO and NiO are the most common choices of oxidant. CuO is the better reagent at temperatures below ~800°C, whereas NiO becomes favorable at higher temperatures. The variation arises from the temperature dependence of O₂ partial pressure over those reagents [25]. A widely applicable solution developed by ThermoElectron is to include both CuO and NiO in the reactor, together with Pt as a catalyst, operated at 900–950°C [55]. For exceptionally stable molecules such as methane, temperatures up to 1150°C must be used, and in these conditions NiO is typically the sole oxidant [56].

O₂ is consumed by the combustion of both analytes and column bleed, and the oxidizing reagents in the combustion reactor must be regenerated. This can be done periodically – typically each night – by flushing the reactor with high concentrations of O₂ while diverting flow from the IRMS. Alternatively, the regeneration can be continuous by adding a small amount of O₂ to the carrier gas at a point between the analytical column and combustion reactor [25]. The size of this “O₂ trickle” must be carefully adjusted so as not to damage the IRMS filament, and a

common practice is to set its flow to produce a ~20 nA ion current at *m/z* 32 in the IRMS. The addition of a reduction reactor downstream from the combustion reactor (see below) can limit the amount of O₂ reaching the ion source, but must be frequently regenerated or replaced if O₂ is continuously added. Both methods of regenerating oxidants can be employed simultaneously.

The combustion reactor is often a major source of peak broadening in GC-IRMS, and considerable effort has gone into optimizing its physical design. Two approaches are now common. The first utilizes a narrow-bore glass or ceramic tube, typically 0.5 mm inner diameter. Reagent metal wires (Cu, Ni, and/or Pt), ~0.1 mm diameter, are twisted together and threaded into the tube [25, 55]. The assembled reactor tube is inserted into a resistively heated tube furnace, connected to fused-silica capillaries at each end (Fig. 5), and oxidized in place by the addition of O₂. This design is the most durable and easiest to assemble, but does produce modest peak broadening. The second common approach uses a single fused-silica capillary as both the combustion reactor and transfer capillaries, with metal wires positioned at the point where the capillary is heated [57, 58]. Because fittings and changes in internal diameter are eliminated, it produces virtually no peak broadening. However, it is tricky to assemble and easily broken where the polyimide coating is burned off the capillary exterior. Fortification of the capillary with an external ceramic or metal tube is helpful.

The combustion of organic species produces H₂O as a major byproduct, and NO_x and SO_x as minor byproducts if organic N and S are present. NO_x and SO_x are corrosive to the mass spectrometer, but more importantly NO₂⁺ is an isobaric interference with ¹²C¹⁸O¹⁶O⁺ at *m/z* 46. Elimination of these species by reduction is accomplished by passing combustion gases over elemental Cu at 500–700°C. This step is sometimes omitted when analytes contain little or no N and S, although this also negates the secondary role of the reduction reactor as an O₂ scrubber. Water must also be reduced to a low concentration because it can participate in proton-transfer reactions within the IRMS ion source, leading to formation of ¹²C¹⁶O₂H⁺ which interferes with ¹³C¹⁶O₂⁺ at *m/z* 45 [59]. Removal of water from the combustion gases is typically accomplished *via* a countercurrent drier based on a selectively permeable membrane of the sulfonated fluoropolymer Nafion™. Construction and operation of these driers have been described in detail by Leckrone and Hayes [60]. Although they are more effective (producing a lower dew point) at colder temperatures, operation of Nafion driers at room temperature is generally adequate. Cryogenic water traps are also occasionally used (*e.g.*, [58]), and while they require periodic defrosting they also eliminate another source of peak broadening.

4.1.2 Nitrogen isotopes

Nitrogen isotopic analysis is also based on combustion of analytes, followed obligately by reduction of NO_x to N_2 [61–63]. Conveniently, the conversion can be accomplished using the same combination of combustion/reduction reactors that are used for carbon (above) so that both types of analyses can be performed using the same interface. Considerations governing the choice and regeneration of oxidizing reagents are the same as for carbon. An additional problem for N-isotopic analyses is that CO_2 entering the IRMS produces significant ion-currents at m/z 28 and 29 due to CO^+ fragments. CO_2 must therefore be removed from the carrier gas stream, generally by cryogenic trapping [26, 61, 63].

4.1.3 Hydrogen isotopes

Early attempts at hydrogen-isotopic analysis utilized serial combustion and reduction, but suffered from short reactor lifetimes due to the continual bleed of O_2 from the combustion reactor into the reduction reactor [64]. Pyrolysis over reduced carbon eliminates that problem [29], as well as the possibility of memory effects associated with metal reductants [28], and is now almost ubiquitous in its use. Burgoyne and Hayes [30] were the first to show that quantitative pyrolysis can be achieved without metal reductants by using a carbon-lined reactor heated to $>1440^\circ\text{C}$. At this temperature, organic analytes are converted to H_2 and either solid carbon (carbon black) or CO , depending on the presence of oxygen. At lower temperatures methane is a significant product, and fractionation is induced by the nonquantitative conversion to H_2 [30]. Nichrome resistance heaters cannot reach such high temperatures, and most pyrolysis interfaces use silicon carbide resistance elements such as those sold by Kanthal-Globar (Amherst, NY). The high temperatures required by pyrolysis are also above the softening temperature for quartz, so high-purity Al_2O_3 reactor tubes are employed.

As for combustion, several tradeoffs affect the choice of operating conditions for the pyrolysis reactor. As temperatures rise above $\sim 1400^\circ\text{C}$, alumina tubes slowly develop microscopic fractures that allow air to diffuse into the reactor (Burgoyne, unpublished data). The process is probably caused by the high thermal gradients experienced by the tube, and development of leaks is more rapid at higher temperatures. At the same time, lower pyrolysis temperatures require a longer residence time for analytes in the heated zone to achieve quantitative conversion to H_2 . This can be accomplished either by reducing carrier-gas flow rates (thus decreasing chromatographic resolution and increasing retention time) or by increasing the diameter of reactor tubes (thus increasing peak broadening) [65]. A typical compromise solution employs a 0.5 or 0.8 mm inner-diameter alumina tube,

GC flow rates of 1.2–1.5 mL/min, and a temperature of 1420 – 1440°C [31, 53]. Used continuously at this temperature, alumina tubes must commonly be replaced every 2–4 wk. The use of other ceramic materials for reactor tubes has not been reported, but may yield some improvement in the situation.

Many users have observed, though seldom published, the need for “conditioning” pyrolysis reactors prior to each use [65]. Common conditioning procedures include the injection of 1–2 μL of organic solvent, the addition of a highly concentrated analyte to the beginning of each chromatogram, or backflushing the reactor with CH_4/He . Although still poorly understood, the necessity for this procedure is probably related to regeneration of a carbon coating within the alumina reactor tube. O_2 and H_2O in the carrier gas oxidize this coating, requiring more frequent regeneration. Conversely, large deposits of carbon within the pyrolysis reactor are undesirable as they can lead to memory effects whereby the isotopic compositions of analytes, column bleed, *etc.* subtly influence those of following analytes. This effect is commonly manifested as a decrease in the normalization slope ([66]; see also Section 6.2.3) and is presumably due to retention of small amounts of hydrogen within the carbon coating. Conditioning pyrolysis reactors to yield highly precise and accurate results remain as much art as science.

Pyrolysis of organic compounds does not yield H_2O as a product. Moreover, traces of H_2O present in the carrier gas are converted to CO and H_2 . Thus Nafion-based driers are not required, and in fact their presence typically increases the partial pressure of H_2O in the gas stream [66]. Similarly, organic N and S are pyrolyzed to yield species (likely N_2 and S, though this has not been confirmed) that do not need to be scrubbed from the gas stream. The most troublesome contaminants for pyrolysis are halogens, which are converted to their corresponding mineral acids (HF , HCl , *etc.*). Not only are such species damaging to the IRMS, but also isotopic fractionation between H_2 and HX leads to inaccurate isotopic measurements. No H-isotopic analyses of halocarbons by GC-IRMS have yet been reported, though Armbruster *et al.* [67] have recently reported the successful use of Cr to remove Cl from the pyrolysis products of polychlorinated organic compounds in an EA-IRMS system.

4.1.4 Oxygen isotopes

Commercial instrumentation for ^{18}O analysis of organic compounds by GC-P-IRMS has been available for more than 5 years. Still, published reports are appearing only slowly and focus primarily on its application for biochemical tracing [68] and natural products authentication [69–72] rather than on experimental details. No comprehensive study of analytical methodology for ^{18}O analysis by GC-IRMS has yet been published.

All GC-IRMS analyses of organic O rely on pyrolysis and reduction of organic molecules over carbon to quantitatively yield CO as the analyzed species. An additional concern for CO (relative to H₂) is the possibility of isotopic exchange between CO and Al₂O₃ in the high-temperature pyrolysis reactor. For this reason, most systems utilize pyrolysis reactors constructed of alumina (typically 0.8 mm id) and lined with Pt or Ni tubes [68, 70, 71]. Pyrolysis/reduction reactors must be conditioned as for HD analyses by the periodic injection of organic compounds [70], and are typically operated at temperatures of 1200–1300°C. Ni wires are sometimes added as a catalyst and reductant, and 1% H₂ is commonly added to the helium carrier gas to maintain reducing conditions [69]. Optimal reactor conditions for ¹⁸O analysis of bulk organics by elemental analyzer (EA-P-IRMS) have been studied more extensively, and are reviewed by Werner [7]. An additional concern for ¹⁸O analysis is that organic N will be converted to N₂, an isobaric interference for CO at *m/z* 28. While CO and N₂ can be separated chromatographically in EA-based measurements, this has not yet been reported for GC-IRMS.

4.2 Solvent diversion

Combustion and pyrolysis reactors are optimized to receive nanogram quantities of analytes. Allowing solvent peaks to enter those reactors leads to a variety of problems, including consumption of oxidizing power (combustion) or deposition of large amounts of carbon (pyrolysis), and a pressure fluctuation that is often sufficient to trip the protection circuitry within the IRMS ion source. GC-IRMS interfaces thus use one of two methods to divert the solvent peak from the reactor. The most common approach involves two valves positioned before and after the reactor (Fig. 5). By simultaneously opening both valves, helium is added such that flow through the reactor is reversed and GC column effluent is vented to the atmosphere [25, 73]. Such a system is commonly called “backflushing,” and is operated under computer control. A second system developed by Brenna *et al.* [6] uses a gas-switching rotary valve upstream from the reactor, whereby the GC column effluent is replaced by a stream of clean He. Although conceptually more elegant, this approach has not been widely adopted, probably because of maintenance issues with the rotary valve caused by frequent temperature cycling of the GC oven.

4.3 Pressure buffering

Combustion or pyrolysis of large organic molecules into low-molecular-weight species leads to a large increase in gas volume. As a concrete example, consider a chromatographic peak 6 s wide in a column with volumetric flow rate of 1.0 mL/min. The total volume occupied by this peak (carrier gas + analyte) would be 0.1 mL, and at

1 atm pressure and 25°C would represent 4.1 nmol of an ideal gas. Such a peak might easily contain 0.1 nmol of analyte, for example, decane. Upon combustion, the decane would be converted to 1 nmol CO₂ and 1.1 nmol H₂O, increasing the gas volume (at constant pressure) by nearly 50%.

If the pressure pulse generated by this combustion were allowed to reach the IRMS ion source, the result would be dynamic changes in the isotopic fractionation accompanying ionization. Accurate comparison of sample and standard peaks would be rendered impossible. To avoid the situation, GC-IRMS interfaces incorporate an open split that provides a constant gas flow rate to the IRMS. In practice, this is achieved by inserting a small (typically 0.11 mm id) capillary ~5 mm into the bore of the larger (0.32 mm id) transfer capillary [25]. The junction is contained in a tube or fitting, bathed in He, and maintained at 1 atm pressure. Because the smaller capillary represents a limiting conductance, flow into the IRMS is governed only by the pressure drop across the capillary, which is constant. Any excess flow is vented to the atmosphere. Similar devices are used in other types of MS.

5 Isotope-ratio MS

A recent review by Brand [13] provides a detailed account of modern IRMS instruments, so only a brief description is provided here with specific reference to GC-IRMS applications. All IRMS instruments use electron-impact ionization sources, a single magnetic-sector analyzer, and multiple Faraday detectors for analog measurement of ion currents (Fig. 2). This arrangement, though seemingly archaic in its similarity to the earliest mass spectrometers [2], remains the best choice for maximizing ionization efficiency and transmission, providing large (μA) and stable ion beams, and affording highly stable detection of ion-beam currents.

Ionization sources in IRMS instruments are typically “tight”, providing higher gas pressure in the ionization volume and increasing ionization efficiency. As a result, gas exchange in the ion source is relatively slow, negating the possibility of analyzing chromatographic peaks less than a few seconds in width. The energy of ionizing electrons is typically 50–150 eV, and is adjusted separately for each gas species to maximize both the yield of molecular ions and the “linearity” of the isotope ratio, *i.e.*, minimizing changes in isotope ratio at different ion beam currents. For analysis of D/H ratios, electron energy must also be chosen to limit formation of ⁴He²⁺ which interferes with ¹H₂⁺ at *m/z* 2. Ions are accelerated by either a repeller plate or extraction lens, or some combination of the two. Relatively large extraction potentials – up to 10 kV – are required to minimize ion–molecule reactions in the ion source [13].

Ions are accelerated to typical energies of 2.5–10 keV and are separated in a homogeneous magnetic field. All modern instruments designed for GC-IRMS utilize electromagnets to provide a mass range that is typically 1–80 amu at 3 kV accelerating voltage. The design of these instruments requires a relatively large electromagnet, and magnet hysteresis is significant. While IRMS instruments are capable of scanning across mass ranges, the process is slow (typically <1 amu/s) and they are thus always operated at a constant magnetic field to monitor a single group of masses. Ion optics are chosen to maximize ion transmission and to limit fluctuations in ion-beam intensity with small changes in magnetic field [13]. The result is the low mass resolution (typically ~100) and flat-topped peaks characteristic of these instruments.

Stability rather than sensitivity is of paramount importance for the detectors, so Faraday cups connected to high-gain (typically 10^8 – 10^{12}) electrometers are utilized for analog measurement of ion currents. The use of multiple detectors to monitor two or three masses simultaneously effectively cancels fluctuations in ion beam intensity [2] and obviates the need for peak jumping. While the design of the Faraday detectors themselves has changed little over the past 50 years, reducing noise and stray capacitance in the electrometers remain an area of active development, particularly for D/H analyses. Deuterium is the least abundant isotope among those commonly measured by a factor of ~10 (Table 1). Given that column overloading remains the chief problem for D/H analyses, and that such analyses do not approach shot-noise limitations within a factor of 100, further improvements in amplifier electronics could yield substantial benefits.

A unique problem for D/H analyses by GC-IRMS is the presence of a $^4\text{He}^+$ ion beam, arising from the carrier gas that is only 1 amu distant and at least six orders of magnitude larger than the HD^+ ion beam. Normally, the overlap of a low-energy tail from this intense $^4\text{He}^+$ beam into the m/z 3 detector dwarfs the HD^+ signal that is to be measured. The low-energy tail is caused by collisions with neutral molecules in the flight path, and is unavoidable in a single-focusing instrument (*i.e.*, without the energy-focusing capability of a double-focusing instrument). Three different solutions have been employed by instrument manufacturers to address the problem: use of a high-dispersion IRMS to further separate HD^+ and $^4\text{He}^+$ ion beams [74], or insertion of a simple electrostatic sector (Micro-mass Application Note 300) or retardation lens [31] in front of the m/z 3 Faraday detector. The latter two approaches are used in essentially all modern instruments.

6 Standardization and data processing

6.1 Standardization

To obtain the highest possible accuracy, isotope-ratio analyses require comparison of sample and standard within each chromatogram [33]. The goals for this standardization are two-fold. First, multiple standards whose isotopic compositions are known with the highest possible accuracy should be introduced at times that bracket analytes as closely as possible. Second, standards and samples should be handled as similarly as possible (the Identical Treatment Principle; [75]) to minimize the impact of isotopic fractionations due to injection, chromatography, chemical conversion, gas transfer, *etc.* The two goals are generally incompatible with a single strategy for standardization. The first is adequately met by introducing a reference gas (CO_2 , H_2 , N_2 , *etc.*) from a large reservoir of known isotopic composition. This is frequently accomplished by the addition of a second, small stream of helium – typically 30 $\mu\text{L}/\text{min}$ or less – flowing directly into the IRMS ion source. Peaks of reference gas are added to this carrier stream either by rotary sampling valve [6] or more commonly by an arrangement of moveable capillaries [9, 76]. Either combines the benefits of using a single reference gas, whose isotopic composition can be measured very precisely, with the flexibility to introduce standards whenever needed. They both suffer from the fundamental drawback that reference gas peaks do not experience the same conditions as do analyte peaks (goal 2), particularly with respect to the chemical conversion interface.

To provide identical treatment of sample and standard, the preferred approach is coinjection of organic standards with known isotopic composition and, ideally, similar chemical composition to the analytes [76]. For this to work, standards that elute in analyte-free regions of the sample chromatogram must be available. Preparation and isotopic analysis of multiple organic standards are time-consuming, but in cases where simple mixtures are analyzed repeatedly – *e.g.*, fatty acids from vegetable oils – the approach can work well. For environmental samples, in which analyte-free regions are rare to non-existent and frequently vary with every sample, coinjection of multiple standards becomes problematic.

Merritt *et al.* [76] compared the use of reference gas and coinjected organic standards for isotopic calibration, and concluded that either can provide equivalent accuracy in the absence of fractionations during combustion of analytes. However, they caution that such fractionations are common when combustion performance is not optimal, and demonstrated that systematic offsets of up to 2‰ (for $\delta^{13}\text{C}$) can result when only reference gas peaks are used for calibration. The optimal solution – with due regard to the problems posed by complex chromato-

grams noted above – is thus to introduce both reference gas and coinjected standards. The former is used for isotopic calibration, while comparison with the latter allows for assessment of systematic biases due to analyte processing.

A compromise approach that has been suggested by Meier-Augenstein [77] involves the generation and addition of peaks of an organic reference gas, *e.g.*, butane, to the carrier gas at a point immediately prior to the combustion or pyrolysis reactor. This approach combines the flexibility of an external reference gas with the ability to correct for fractionation during the chemical conversion of analytes. Although simple and elegant in its approach, it has not yet been adopted by the manufacturers of IRMS instrumentation.

The paucity of widely available, GC-amenable organic standards of known isotopic composition remains a significant problem for practitioners of GC-IRMS. There are no internationally recognized stable isotope reference materials that can be analyzed by GC-IRMS [78]. Only one commercial vendor (Chiron, Trondheim, Norway) sells *n*-alkanes, ranging from C₁₁ to C₄₀, of known ¹³C composition. Recently, Arndt Schimmelmann (Indiana University) has begun making organic standards of known ¹³C and ²H composition available to the research community at nominal cost. No organic O-isotopic standards are available, and standardization for ¹⁸O analyses remains particularly problematic [79]. Most labs currently generate their own standard compounds by calibration using other forms of isotopic analysis, but this leads to obvious concerns about intercalibration between laboratories. There have as yet been no intercalibration exercises to test the reproducibility of GC-IRMS results between different laboratories.

6.2 Data processing

Processing of GC-IRMS data comprises three steps. First, raw data must be corrected for the presence of the interfering isobars H₃⁺ (D/H analyses), ¹³C¹⁷O (CO analyses), or ¹²C¹⁷O¹⁶O (CO₂ analyses). No isobaric corrections are needed for N₂ analyses. Second, peak areas for each isotopolog of each peak must be integrated and compared to calculate the ion-current ratio for that peak (Fig. 1). Third, ion-current ratios for each sample must be compared to those of standards to calculate isotope ratios (δ values). All of these steps can be accomplished automatically by the instrument software, although user intervention for the selection of appropriate parameters is generally required. A brief summary of the relevant procedures is provided here.

6.2.1 Correction for H₃⁺

H₂ in the IRMS ion source reacts to form H₃⁺ following the reaction [80]:



The abundance of H₂⁺ is proportional to that of H₂, hence the production of H₃⁺ is proportional to the second power of the partial pressure of H₂

$$P_{\text{H}_3^+} = k(P_{\text{H}_2})^2 \quad (3)$$

The abundance of H₃⁺ at any point in the chromatogram can thus be calculated from the abundance of H₂ at the same time if the proportionality constant *k* is known. Sessions *et al.* [34] showed that this correction can be made on a point-by-point basis without introducing significant errors, provided that the time constants in the signal-processing pathways for *m/z* 2 and 3 are faster than the rate at which H₂ signals vary and are approximately equal. The former requirement can be significant because of the high gain (typically 10¹²) and hence large time constants (commonly 0.5 s) present in the *m/z* 3 electrometer, though this problem has been greatly mitigated in the most recent IRMS instruments.

The proportionality constant *k* is generally termed the “H₃-factor” and varies between IRMS instruments as well as over time for any individual instrument. Its value is typically determined daily during D/H analyses by GC-IRMS. Several approaches to determining the H₃-factor under continuous-flow conditions have been described. The simplest, and hence most common, is to introduce a series of reference-gas peaks of identical isotopic composition but varying amplitude. The value of *k* is taken as that which minimizes differences in δD values between the peaks. A more complete but laborious solution involves the analysis of a standard mixture containing multiple peaks of varying concentration and, by necessity, isotopic composition [66]. This approach has the added advantage of accounting for nonlinearities in isotope ratio induced by the pyrolysis of analytes to H₂. The value of *k* can – in theory – also be determined from a single chromatographic peak of known isotopic composition, a procedure that would allow the H₃-factor to be evaluated both quickly and repeatedly in every chromatogram [66]. However, this approach requires very fast and closely matched electrometer time constants, and has not yet been realized in any commercially available instruments.

6.2.2 Peak integration

Because GC-IRMS measurements must deal simultaneously with peaks collected at multiple masses, shifted in time by isotope chromatography, all while maintaining the highest possible accuracy and precision, approaches for peak integration are more complex than in typical GC-MS. Ricci *et al.* [44] provide a detailed discussion of the relevant issues, which are summarized here. Peak integration intervals (start and stop times) are typi-

cally evaluated using the mass chromatogram for the major isotopic mass (*i.e.*, m/z 2 for H₂, 28 for N₂, *etc.*), which has the highest signal/noise ratio. This integration interval can then be transferred to the data for other masses, with the caveat that they must be shifted in time to account for the effects of isotope chromatography. This is accomplished by comparing the retention times for the peak maxima in each mass chromatogram. Ricci *et al.* [44] describe a procedure for precisely determining each peak maximum by fitting a parabola to the peak-top data, allowing the time-shift for the integration interval to be a fraction of a single data point. This procedure assumes that peak-widths are identical for each of the isotopic peaks, a requirement that is not fully realized but that also does not seem to contribute significant errors.

Next, background signals must be determined individually for each mass chromatogram, and subtracted on a point-by-point basis across the integration interval. A typical procedure involves averaging a (user-selectable) number of data points before and after each peak, and linearly interpolating between them. Smoothing or curve-fitting of data to provide more accurate backgrounds is possible but tricky, because the data stream for each isotopic mass contains different noise sources filtered through (slightly) different time constants. A variety of methods for determining background signals are available in each instrument software package, but a detailed comparison of the strengths and weaknesses of various methods has not yet been published.

Finally, the peak area for each isotopic peak is calculated by summing the background-corrected data points within the integration interval, and the ion-current ratio is calculated for each compound by comparing the areas for the isotopologs. This summation is typically performed on a point-by-point basis. Goodman and Brenna [46] have described a more advanced method for summation based on curve-fitting of each peak that provides improved accuracy at low signal/noise levels.

6.2.3 Calculation of isotope ratios

Delta values (δD , $\delta^{13}C$, $\delta^{15}N$, *etc.*) are, in essence, calculated using the relationship described by Eq. (1). The calculation is complicated by the fact that multiple standards are introduced, and they almost never have the same isotopic composition as the international reference standard (SMOW, PDB, *etc.*). Details of the necessary calculations are described by Ricci *et al.* [44]. In an ideal chromatogram, a single standard would be sufficient to calibrate all analyte peaks. In reality, δ values become less accurate as sample/standard pairs are more widely separated due to the effects of instrument drift [33]. To compensate for drift, most software interpolates linearly between the two closest standards to calculate the isotope ratio of a

(hypothetical) standard eluting at the same retention time as the analyte. While this approach is usually satisfactory, more sophisticated methods for simultaneously minimizing errors in all standard peaks in a chromatogram would be a welcome addition.

Once delta values have been calculated, a process termed “normalization” is sometimes employed in an effort to ensure that data from all laboratories are comparable [34, 81]. The problem arises from an effect termed “scale compression” in IRMS instruments. While the root causes of scale compression are complex, the net effect is easily understood *via* an example. If two IRMS instruments (A and B) measured a suite of water samples, and the resulting δD values were compared, we would find that a plot of δD_A versus δD_B for all samples formed a straight line but with a slope differing from unity. The effect is most pronounced for H and O, and normalization is commonly utilized for these elements. Normalization is rarely used for C or N, though the International Atomic Energy Agency (IAEA) now recommends that all ¹³C analyses be corrected for scale normalization based on two or more standards [82]. In practice, a normalization line is constructed by analyzing a suite of standards of known isotopic compositions varying over the range of expected δ values. This is straightforward for samples with natural isotopic abundances, but quite problematic for samples that have been artificially enriched (or depleted) in the rare isotope because of the lack of suitable standards.

7 Summary

High-precision isotope-ratio detection of gas chromatographic analytes is now a mature technology, and is enjoying widespread growth in a variety of fields including biogeochemistry and paleoclimatology, archaeology, petroleum chemistry, environmental forensics, flavor and fragrance authentication, drug testing, metabolite tracing, and others. Instrumentation and software are commercially available and fully automated, and their use and maintenance no longer demand a cadre of highly trained technicians. Ongoing methodological improvements are focused primarily on adaptation to more diverse analytes, and on more sophisticated methods for improving chromatographic resolution and capacity.

In the future, we may expect several areas of development. Analysis of organic S appears feasible if problems related to its low elemental abundance can be resolved. Replacement of conventional gas-source IRMS instruments by multicollector ICP-MS will likely provide for the analysis of monoatomic ions with high enough precision to enable isotopic measurements of halogens, sulfur, and other elements [83, 84]. Plasma ion sources also

offer the potential for greatly improved ionization efficiency [85], and hence lowered detection limits for all elements. Several groups have begun reporting the first steps toward high-precision analyses of the intramolecular isotopic distribution of organic molecules [86–89]. Techniques of isotope-ratio detection for LC are currently in their infancy [90–92].

The author is particularly indebted to C. Douthitt for answering many questions about the historical development of GC-IRMS methods, for numerous references, and for a thorough review of the manuscript. The kind help of W. Brand and J. Hayes is further acknowledged. ALS is supported by NSF EAR-0311824.

8 References

- [1] Nier, A. O., Gulbransen, E. A., *J. Am. Chem. Soc.* 1939, 61, 697–698.
- [2] McKinney, C. R., McCrea, J. M., Epstein, S., Allen, H. A., Urey, H. C., *Rev. Sci. Instrum.* 1950, 21, 724–730.
- [3] Sano, M., Yotsui, Y., Abe, H., Sasaki, S., *Biomed. Mass Spectrom.* 1976, 3, 1–3.
- [4] Matthews, D. E., Hayes, J. M., *Anal. Chem.* 1978, 50, 1465–1473.
- [5] Gehre, M., Strauch, G., *Rapid Commun. Mass Spectrom.* 2003, 17, 1497–1503.
- [6] Brenna, J. T., Corso, T. N., Tobias, H. J., Caimi, R. J., *Mass Spectrom. Rev.* 1997, 16, 227–258.
- [7] Werner, R., *Isotopes Environ. Health Stud.* 2003, 39, 85–104.
- [8] de Groot, P. A., *Handbook of Stable Isotope Analytical Techniques*, Elsevier, Amsterdam 2004, Vol. 2, p. 1234.
- [9] Brand, W. A., *J. Mass Spectrom.* 1996, 31, 225–235.
- [10] Meier-Augenstein, W., in: de Groot, P. A. (Ed.), *Handbook of Stable Isotope Analytical Techniques*, Elsevier, Amsterdam 2004, pp. 153–176.
- [11] Brenna, J. T., *Acc. Chem. Res.* 1994, 27, 340–346.
- [12] Hayes, J. M., in: Meinschein, W. G. (Ed.), *Organic Geochemistry of Contemporaneous and Ancient Sediments*, Society of Economic Paleontologists and Mineralogists, Bloomington, IN 1983, pp. 5.1–5.31.
- [13] Brand, W. A., in: de Groot, P. A. (Ed.), *Handbook of Stable Isotope Analytical Techniques*, Elsevier, Amsterdam 2004, pp. 835–856.
- [14] Criss, R. E., *Principles of Stable Isotope Distribution*, Oxford University Press, New York 1999.
- [15] Bigeleisen, J., Wolfsberg, M., *Adv. Chem. Phys.* 1958, 1, 15–76.
- [16] Cleland, W. W., *J. Biol. Chem.* 2003, 278, 51975–51984.
- [17] di Corcia, A., Liberti, A., *Trans. Faraday Soc.* 1969, 66, 967–975.
- [18] Höpfner, A., *Angew. Chem.* 1969, 8, 689–699.
- [19] Knyazev, D. A., Myasoedov, N. F., Bochkarev, A. V., *Russ. Chem. Rev.* 1992, 61, 204–220.
- [20] O'Leary, M. H., *Phytochemistry* 1981, 20, 553–567.
- [21] O'Leary, M. H., *Bioscience* 1988, 38, 328–336.
- [22] Mayer, B., Krouse, H. R., in: de Groot, P. A. (Ed.), *Handbook of Stable Isotope Analytical Techniques*, Elsevier, Amsterdam 2004, pp. 538–596.
- [23] Urey, H. C., *Science* 1948, 108, 489–496.
- [24] Urey, H. C., Epstein, S., McKinney, C., McCrea, J., *Geol. Soc. Am. Bull.* 1948, 59, 1359–1360.
- [25] Merritt, D. A., Freeman, K. H., Ricci, M. P., Studley, S. A., Hayes, J. M., *Anal. Chem.* 1995, 67, 2461–2473.
- [26] Brand, W. A., Tegtmeier, A. R., Hilker, A., *Org. Geochem.* 1994, 21, 585–594.
- [27] Barrie, A., Bricout, J., Koziat, J., *Biomed. Mass Spec.* 1984, 11, 583–588.
- [28] Begley, I. S., Scrimgeour, C. M., *Anal. Chem.* 1997, 69, 1530–1535.
- [29] Tobias, H. J., Brenna, J. T., *Anal. Chem.* 1997, 69, 3148–3152.
- [30] Burgoyne, T. W., Hayes, J. M., *Anal. Chem.* 1998, 70, 5136–5141.
- [31] Hilker, A. W., Douthitt, C. B., Schlüter, H. J., Brand, W. A., *Rapid Commun. Mass Spectrom.* 1999, 13, 1226–1230.
- [32] Brand, W. A., in: Karjalainen, E. J., Hesso, A. E., Jalonen, J. E., Karjalainen, U. P. (Eds.), *Advances in Mass Spectrometry*, Elsevier, Amsterdam 1998, vol. 14, pp. 661–686.
- [33] Merritt, D. A., Hayes, J. M., *Anal. Chem.* 1994, 66, 2336–2347.
- [34] Sessions, A. L., Burgoyne, T. W., Hayes, J. M., *Anal. Chem.* 2001, 73, 192–199.
- [35] Douthitt, C. B., *Analysis* 1999, 27, 197–199.
- [36] Meier-Augenstein, W., *J. Chromatogr. A* 1999, 842, 351–371.
- [37] Wang, Y., Huang, Y., *Org. Geochem.* 2001, 32, 991–998.
- [38] Li, M., Huang, Y., Obermajer, M., Jiang, C. et al., *Org. Geochem.* 2001, 32, 1387–1399.
- [39] Dias, R. F., Freeman, K. H., *Anal. Chem.* 1997, 69, 944–950.
- [40] Harris, S. A., Whiticar, M. J., Eek, M. K., *Org. Geochem.* 1999, 30, 721–737.
- [41] Dayan, H., Abrajano, T., Sturchio, N. C., Winsor, L., *Org. Geochem.* 1999, 30, 755–763.
- [42] Zwank, L., Berg, M., Schmidt, T. C., Haderlein, S. B., *Anal. Chem.* 2003, 75, 5575–5583.
- [43] Goldstein, A. H., Shaw, S. L., *Chem. Rev.* 2003, 103, 5025–5048.
- [44] Ricci, M. P., Merritt, D. A., Freeman, K. H., Hayes, J. M., *Org. Geochem.* 1994, 21, 561–571.
- [45] Freeman, K. H., Hayes, J. M., Trendel, J.-M., Albrecht, P., *Nature* 1990, 343, 254–256.
- [46] Goodman, K. J., Brenna, J. T., *J. Chromatogr. A* 1995, 689, 63–68.
- [47] Goodman, K. J., Brenna, J. T., *Anal. Chem.* 1994, 66, 1294–1301.
- [48] Horii, Y., Kannan, K., Petrick, G., Gamo, T. et al., *Environ. Sci. Technol.* 2005, 39, 4206–4212.
- [49] Sewenig, S., Bullinger, D., Hener, U., Mosandl, A., *J. Agric. Food Chem.* 2005, 53, 838–844.
- [50] Akard, M., Sacks, R., *Anal. Chem.* 1994, 66, 3036–3041.
- [51] Schimmelmann, A., *Anal. Chem.* 1991, 63, 2456–2459.

- [52] Valentine, D. L., Sessions, A. L., Tyler, S. C., Chidthaisong, A., *Geobiology* 2004, 2, 179–188.
- [53] Sessions, A. L., Burgoyne, T. W., Schimmelmänn, A., Hayes, J. M., *Org. Geochem.* 1999, 30, 1193–1200.
- [54] Sauer, P. E., Eglinton, T. I., Hayes, J. M., Schimmelmänn, A., Sessions, A. L., *Geochim. Cosmochim. Acta* 2001, 65, 213–222.
- [55] Brand, W. A., Patent application GB-2270911-A (UK), Finningan MAT GmbH, 1993.
- [56] Merritt, D. A., Hayes, J. M., Des Marais, D. J., *J. Geophys. Res.* 1995, 100, 1317–1326.
- [57] Ellis, L., Fincannon, A. L., *Org. Geochem.* 1998, 29, 1101–1117.
- [58] Goodman, K. J., *Anal. Chem.* 1998, 70, 833–837.
- [59] Leckrone, K. J., Hayes, J. M., *Anal. Chem.* 1998, 70, 2737–2744.
- [60] Leckrone, K. J., Hayes, J. M., *Anal. Chem.* 1997, 69, 911–918.
- [61] Merritt, D. A., Hayes, J. M., *J. Am. Soc. Mass Spectrom.* 1994, 5, 387–397.
- [62] Metges, C. C., Petzke, K. J., Hennig, U., *J. Mass Spectrom.* 1996, 31, 367–376.
- [63] Macko, S. A., Uhle, M. E., Engel, M. H., Andrushevich, V., *Anal. Chem.* 1997, 69, 926–929.
- [64] Tobias, H. J., Brenna, J. T., *Anal. Chem.* 1996, 68, 3002–3007.
- [65] Bilke, S., Mosandl, A., *Rapid Commun. Mass Spectrom.* 2002, 16, 468–472.
- [66] Sessions, A. L., Burgoyne, T. W., Hayes, J. M., *Anal. Chem.* 2001, 73, 200–207.
- [67] Armbruster, W., Lehnert, K., Vetter, W., *Anal. Bioanal. Chem.* 2006, 384, 237–243.
- [68] Gremaud, G., Piguët, C., Baumgartner, M., Pouteau, E. et al., *Rapid Commun. Mass Spectrom.* 2001, 15, 1207–1213.
- [69] Aguilar-Cisneros, B. O., Lopez, M. G., Richling, E., Heckel, F., Schreier, P., *J. Agric. Food Chem.* 2002, 50, 7520–7523.
- [70] Jung, J. C., Sewenig, S., Hener, U., Mosandl, A., *Eur. Food Res. Technol.* 2005, 220, 232–237.
- [71] Hener, U., Brand, W. A., Hilker, A. W., Juchelka, D. et al., *Z. Lebensm. Unters. FA* 1998, 206, 230–232.
- [72] Ruff, C., Hör, K., Weckerle, B., König, T., Schreier, P., *J. Agric. Food Chem.* 2002, 50, 1028–1031.
- [73] Goodman, K. J., Brenna, J. T., *Anal. Chem.* 1992, 64, 1088–1095.
- [74] Prosser, S. J., Scrimgeour, C. M., *Anal. Chem.* 1995, 67, 1992–1997.
- [75] Werner, R. A., Brand, W. A., *Rapid Commun. Mass Spectrom.* 2001, 15, 501–519.
- [76] Merritt, D. A., Brand, W. A., Hayes, J. M., *Org. Geochem.* 1994, 21, 573–583.
- [77] Meier-Augenstein, W., *Rapid Commun. Mass Spectrom.* 1997, 11, 1775–1780.
- [78] Gröning, M., in: de Groot, P. A. (Ed.), *Handbook of Stable Isotope Analytical Techniques*, Elsevier, Amsterdam 2004, pp. 874–906.
- [79] Kornexl, B. E., Werner, R. A., Gehre, M., *Rapid Commun. Mass Spectrom.* 1999, 13, 1248–1251.
- [80] Friedman, I., *Geochim. Cosmochim. Acta* 1953, 4, 89–103.
- [81] Coplen, T. B., *Chem. Geol.* 1988, 72, 293–297.
- [82] Coplen, T. B., Brand, W. A., Gehre, M., Gröning, M. et al., *Anal. Chem.* 2006, 78, 2439–2441.
- [83] van Acker, M. R. M., Shahar, A., Young, E. D., Coleman, M., *Anal. Chem.* 2006, 78, 4663–4667.
- [84] Bendall, C., Lahaye, Y., Fiebig, J., Weyer, S., Brey, G. P., *Appl. Geochem.* 2006, 21, 782–787.
- [85] Schneider, R. J., Kim, S. W., von Reden, K. F., Hayes, J. M. et al., *Nucl. Instrum. Methods B* 2004, 223–24, 149–154.
- [86] Corso, T. N., Brenna, J. T., *Anal. Chim. Acta* 1999, 197, 217–224.
- [87] Dias, R. F., Freeman, K. F., Franks, S. G., *Org. Geochem.* 2002, 33, 161–168.
- [88] Wolyniak, C. J., Sacks, G. L., Pan, B. S., Brenna, J. T., *Anal. Chem.* 2005, 77, 1746–1752.
- [89] Yamada, K., Tanaka, M., Nakagawa, F., Yoshida, N., *Rapid Commun. Mass Spectrom.* 2002, 16, 1059–1064.
- [90] Krummen, M., Hilker, A. W., Juchelka, D., Duhr, A. et al., *Rapid Commun. Mass Spectrom.* 2004, 18, 2260–2266.
- [91] Caimi, R. J., Brenna, J. T., *Anal. Chem.* 1993, 65, 3497–3500.
- [92] Brand, W. A., Dobberstein, P., *Isotopes Environ. Health Stud.* 1996, 32, 275–283.